

## SEPARABLE ELBOW CONNECTOR (INTERFACE A/250A)

For polymeric cables – Deadbreak operation – with mechanical conductor contact

**elascon**  
**EC**

REFERENCE: **MSCE/EC -250-A**

### UTILISATION

- For connection of polymeric MV cables to transformers, switchgear units, motors, etc.
- Indoor and outdoor installation. The connector is entirely protected by a watertight conductive envelope connected to earth.
- Continuous 250 A rms
- Overload 300 A rms (8 hours per 24-hour period).
- Operated when de-energized.
- Test by voltage detector through an inbuilt capacitive voltage divider.

### CABLES

- Single core polymeric insulation (PE, XLPE, EPR ...).
- Copper or aluminium conductors, solid or stranded.
- Semi-conducting screen either extruded or taped.
- Metallic screen of tape, wire or polylam type.
- Insulation voltage up to 12.7/22 (24) kV.
- Conductor sizes: 25 to 95 mm<sup>2</sup>.

### STANDARDS

- Generally meets the requirements of CENELEC HD 629.1 S2 – IEC 60502-4 – NF C 33-051 – NF C 33-001.
- Interfaces: CENELEC EN 50180 – EN 50181.
- Mechanical conductor contact: IEC 61238-1 class A, HN 68-S-91.



### QUALITY ASSURANCE

- The company has been assessed by third party and found in conformity with the requirements of the standard ISO 9001-EN 29001 version 2000.

### PACKING

- Supplied as a kit of 3 single connectors containing all the necessary components.
- Shipping weight and volume (approx) of kit : 3 kg / 0,006 m<sup>3</sup>

### INSTALLATION FEATURES

- **For class tension 24kV, only one product reference allows to cover the section from 25 mm<sup>2</sup> to 95 mm<sup>2</sup>, copper or aluminium core.**
- The screen break design enables cable outer sheath testing without removing or dismantling the connector.
- No need for special tools, no heating, taping or filling.
- Vertical, angled or inverted position.
- No minimum distance between phases.
- Individual clamping by stainless steel brace.
- The three phases may also be locked together and to the equipment by use of metallic rings (supplied on request, separately or already fitted into the moulded groove).
- Energizing may take place immediately after the connector is plugged into its bushing, dead-end plug ....
- An unplugged connector must not be energized.

### OTHER PRODUCTS

- Associated products such as bushing FMBOm-250, FMBOh-250, FMBOcm, FMBA-250 and accessories.
- Additional metallic cover.
- Separable straight connector MSCS/EC-250-A.

**SEPARABLE ELBOW CONNECTOR (INTERFACE A/250A)**

For polymeric cables – Deadbreak operation – with mechanical conductor contact

**elascon**  
**EC**REFERENCE: **MSCE/EC -250-A****DESCRIPTION**

- Rep 1 Mechanical conductor contact Al/Cu 25/95 mm<sup>2</sup>.**  
Only one conductor contact covers the section from 25 mm<sup>2</sup> to 95 mm<sup>2</sup>, copper or aluminium core.  
No need for special tools.
- Rep 2 Copper contact pin.**  
Copper pin, screwed into the mechanical conductor contact.
- Rep 3 Semi-conducting inner screen.**  
Insert of semi-conducting EPDM enclosing the metallic connections so that ionization of the air remaining trapped inside is prevented.
- Rep 4 Semi-conducting outer envelope (thickness 3mm).**  
Jacket made of semi-conducting EPDM. Its design provides relief of electrical stress as does a cable screen. Its connection to the cable screen ensures that the assembly is maintained at earth potential.  
It allows to evacuate the short-circuit currents.
- Rep 5 Insulating body.**  
Moulded from insulating EPDM, for integral reconstitution of insulation. It maintains a uniform contact pressure on the cable insulation and on the bushing interface, providing an excellent moisture seal.
- Rep 6 Test point.**  
Electrically protected by a cap made of semi-conducting EPDM. A capacitive voltage divider allows the checking of absence of voltage before removing the connector.
- Rep 7 Locking brace.**  
Stainless steel brace fastening the connector onto its mating bushing or other accessories.
- Rep 8 Earthing eye.**  
For connection of the outer envelope to the metallic cable screen.
- Rep 9 Groove for locking ring.**  
For the fitting of a metallic ring (supplied on request) when 3-phase locking is required.
- Rep 10 Earth cover.**  
Moulded semi-conducting EPDM. Ensures watertight protection of the earthing device.

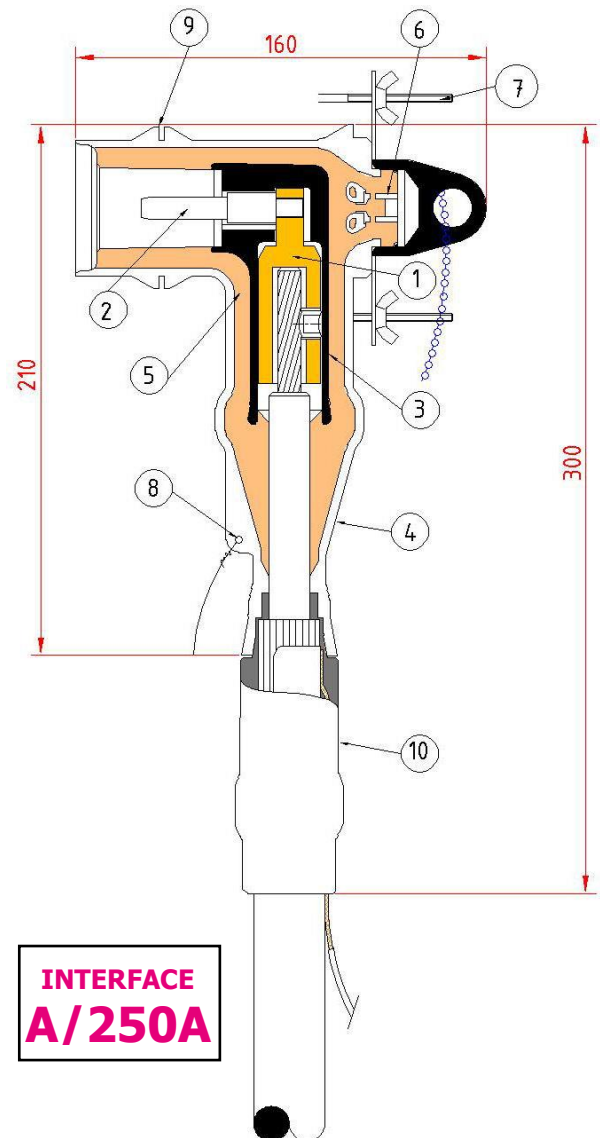

**100% of the separable connectors bodies are individually tested in factory**  
- Industrial power frequency  
and partial discharges -

**The screen break design enables cable outer sheath testing without removing or dismantling the connector.**



**SEPARABLE ELBOW CONNECTOR (INTERFACE A/250A)**  
 For polymeric cables – Deadbreak operation – with mechanical conductor contact

REFERENCE: **MSCE/EC -250-A**

**SELECTION GUIDE**

**Overall dimensions (installed on bushing) in mm**

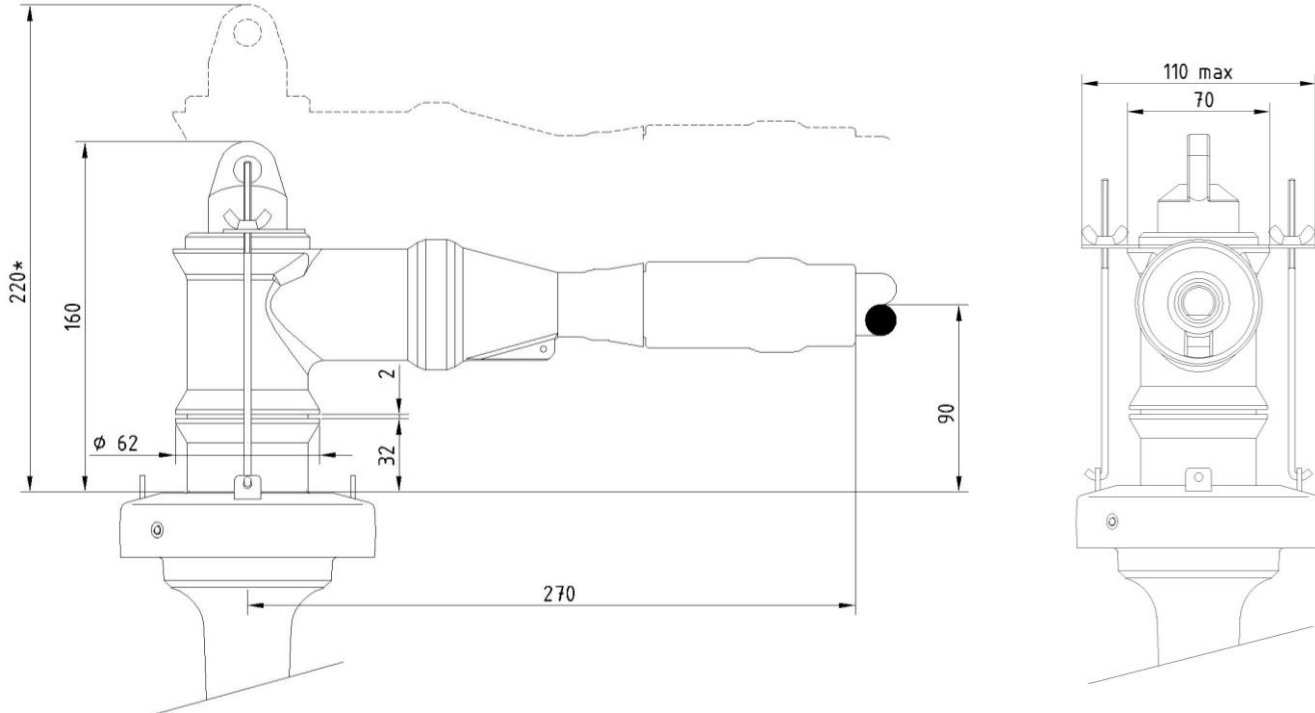

(\*) Minimum dimension required for disconnection

1. Select in the table below the kit model corresponding to the diameter over cable insulation and to the insulation voltage  $U_m$  in kV.

**For cables with reduced insulation thickness, please contact us.**

Voltage	Diam. Over insulation in mm		Conductor size in mm <sup>2</sup> (for guidance only)	Kit reference
	Min.	Max.		
12 kV	11.8	23.2	25 / 95	MSCE/EC-250-A-12-25/95*
17 kV	11.8	23.2	25 / 95	MSCE/EC-250-A-17-25/95*
24 kV	17.2	25	25 / 95	MSCE/EC-250-A-24-25/95

\*: models with adapters, please contact us.

2. Select suitable earthing device in the table below.

Earthing Device Reference	Type of Metallic Screen of Cable
T1	polylam
T2	Copper tape
T3	Copper wires

**EXAMPLE OF ORDER**

20 kV polymeric cable, 1x 50 mm<sup>2</sup>, diameter over insulation 21.5 mm, with copper wire screen, aluminium conductor:  
**MSCE/EC -250-A-24-T3-25/95.**

Metallic ring to lock the 3 connectors together could be supplied on request.